



Bridge Design Details 14.3 January 2023

End Diaphragm – CIP/PS Box Girder

Show limits of deck and soffit slab reinforcement, see Bridge Design Memo 9.4.

Prestress blockout shape can be vertical or inclined and is determined by the Contractor, see Bridge Design Memo 5.26 for anchorage zone design. For other prestress anchorage blockout details, see Standard Plans B8-5. For recommended end diaphragm dimensions, refer to Bridge Design Memo 5.22.

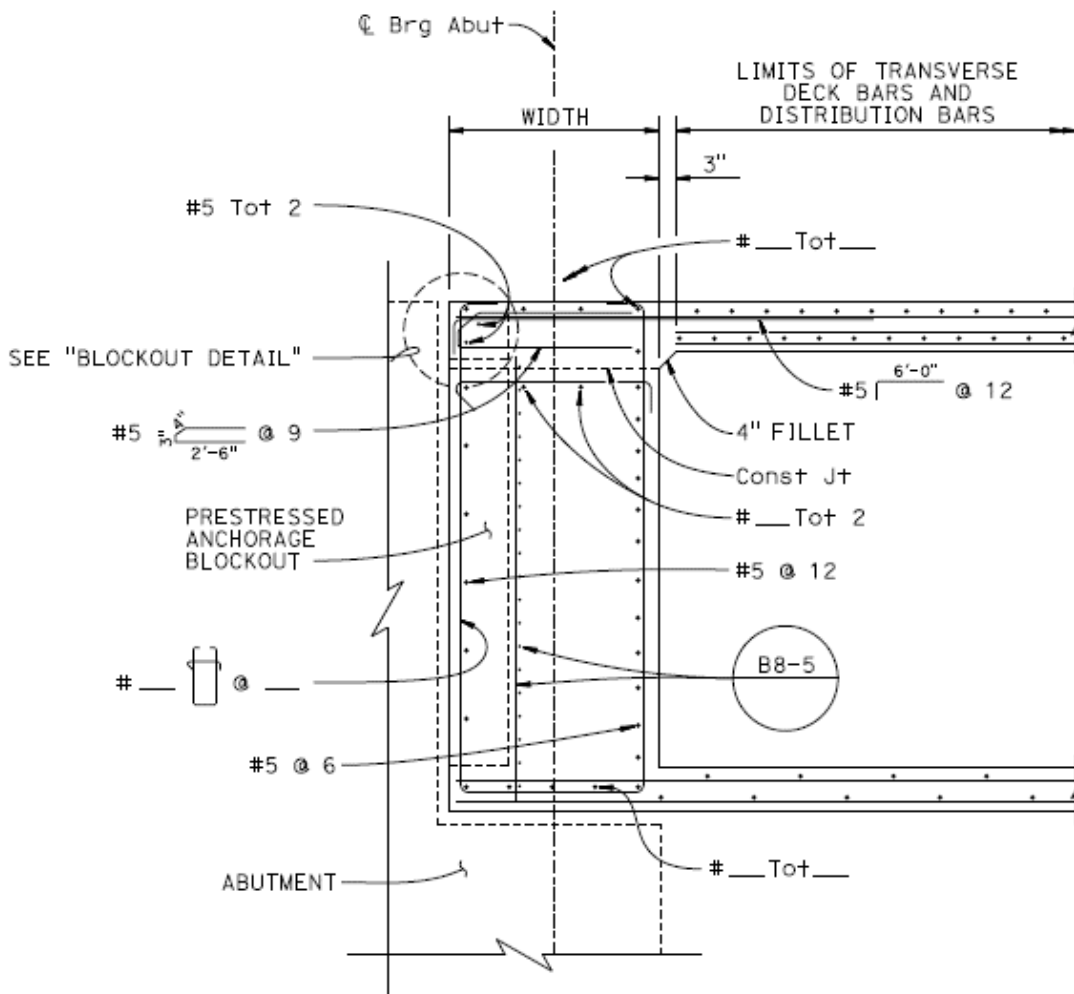

Figure 14.3.1 End Diaphragm Detail