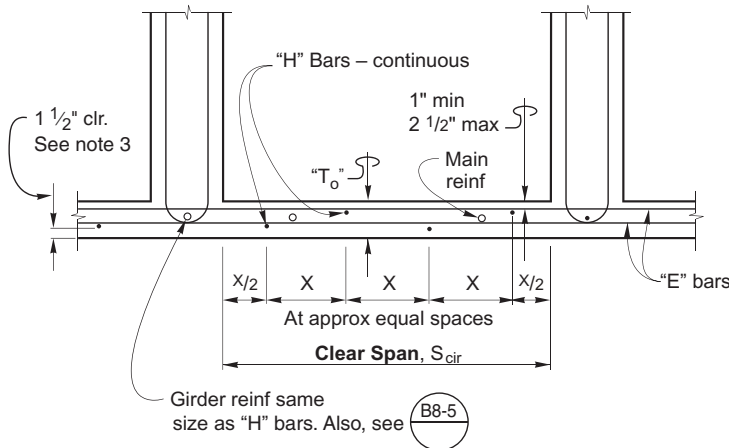
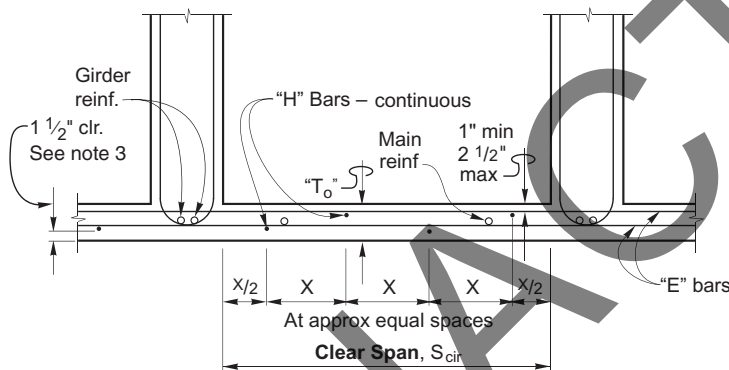

Table 10-20.2 Soffit Slab Reinforcement Details

AASHTO LRFD BRIDGE DESIGN SPECIFICATIONS



Prestressed Concrete Box Girder



Reinforced Concrete Box Girder

NOTES

1. Article (Art.) and table numbers correspond to those in the AASHTO LRFD Bridge Design Specifications
2. X = Bar Spacing
3. Increase cover for environmental conditions as required. See Art (5.12.3)
4. 'E' bars and 'H' bars are per Art. 5.14.1.5.2b, 'T_o' is per Art. 5.14.1.5.1b
5. 'H' bars comply with minimum soffit slab reinforcement requirements and should not be included to calculate resistance under combined effects of DL, LL & Temperature unless an analysis is conducted that considers all those effects.
6. Girder and main reinforcement will be determined by the designer. Main reinforcement is to be shown on girder reinforcement sheet.

S _{gir} Clear Span	"T _o " Min. Bottom slab thick	"E" Bar Spacing	"H" Bars Continuous
			Reinforced and Prestressed Concrete
4' - 0"	6"	#4 @ 13"	4 - #5
4' - 3"			4 - #5
4' - 6"			5 - #5
4' - 9"			
5' - 0"			
5' - 3"			
5' - 6"			6 - #5
5' - 9"			
6' - 0"			
6' - 3"			
6' - 6"			7 - #5
6' - 9"			
7' - 0"			
7' - 3"			
7' - 6"			
7' - 9"			8 - #5
8' - 0"	6"		
8' - 3"	6 1/4"	12"	
8' - 6"	6 3/8"	12"	6 - #6
8' - 9"	6 5/8"	#5 @ 18"	7 - #6
9' - 0"	6 3/4"	18"	7 - #6
9' - 3"	7"	17"	8 - #6
9' - 6"	7 1/8"	17"	
9' - 9"	7 3/8"	16"	
10' - 0"	7 1/2"	16"	7 - #7
10' - 3"	7 3/4"	16"	
10' - 6"	7 7/8"	15"	
10' - 9"	8 1/8"	15"	8 - #7
11' - 0"	8 1/4"	15"	
11' - 3"	8 1/2"	14"	
11' - 6"	8 5/8"	14"	
11' - 9"	8 7/8"	13"	9 - #7
12' - 0"	9"	13"	9 - #7
12' - 3"	9 1/4"	13"	10 - #7
12' - 6"	9 3/8"	13"	
12' - 9"	9 5/8"	12"	
13' - 0"	9 3/4"	12"	11 - #7
13' - 3"	9 3/4"	12"	
13' - 6"	9 7/8"	12"	
13' - 9"	10"	12"	
14' - 0"	10 1/8"	12"	12 - #7
14' - 3"	10 1/4"	12"	
14' - 4"	10 3/8"	11"	